

THIS DRAWING IS UNPUBLISHED.

RELEASED FOR PUBLICATION

REVISIONS

© COPYRIGHT - By -

ALL RIGHTS RESERVED.

P	LTR	DESCRIPTION	DATE	DWN	APVD
	M3	REVISED PER ECR-15-016360	10MAR2016	NK	LP

- 1 CONTINUOUS STRIP ON REEL.
- 2 WIRE RANGE IS 800-2600 CMA
 CRIMP WIDTH: .090, F TYPE
 CRIMP HEIGHT $\pm .002 = (\text{TOTAL CMA} + 6470) / 142,800$
 FOR APPLICATOR INFORMATION CALL: 1-800-722-1111
 FOR PRODUCT INFORMATION CALL: 1-800-522-6752

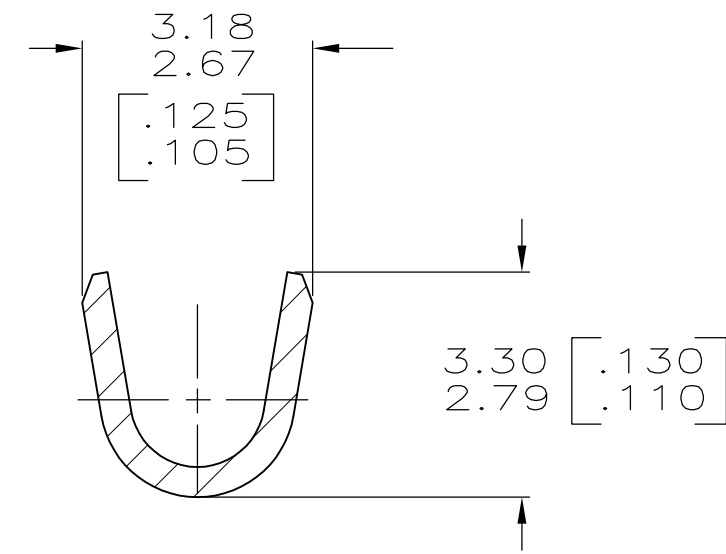
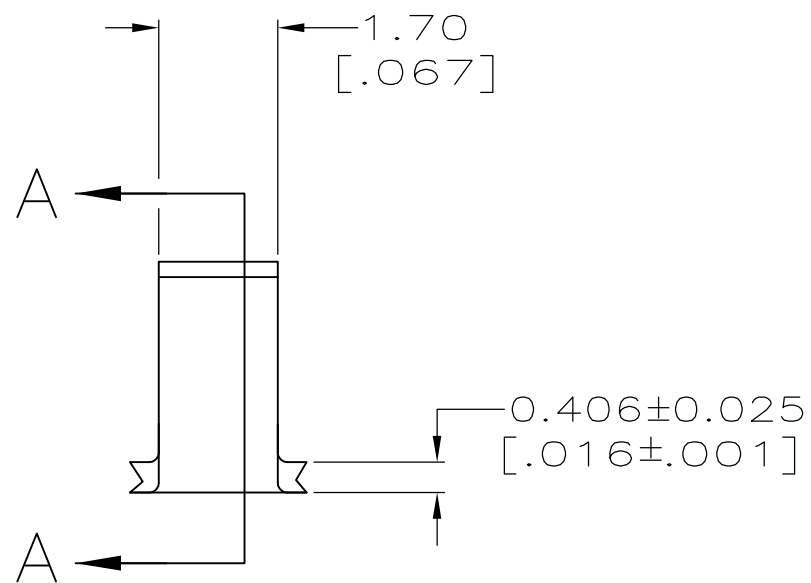
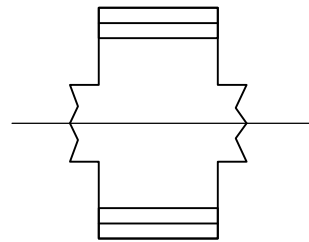

SECTION A-A

	0.0025 [.000100] MIN NICKEL	STEEL (UNS 1008-1010)	41459-3
	0.002032 [.000080] MIN TIN	082 BRASS	41459-2
OBSOLETE	-	COPPER NICKEL C725	41459-1
	-	082 BRASS	41459
	FINISH	MATERIAL	PART NO

THIS DRAWING IS A CONTROLLED DOCUMENT.		DWN PHILLIP M. FORTNEY 8/9/94	STE TE Connectivity															
DIMENSIONS: INCHES		CHK JR RUTH 8/9/94																
TOLERANCES UNLESS OTHERWISE SPECIFIED:		APVD R KUZO 8/9/94	NAME SPLICE															
<table border="0"> <tr><td>0 PLC</td><td>± -</td></tr> <tr><td>1 PLC</td><td>± -</td></tr> <tr><td>2 PLC</td><td>± 0.25 [.010]</td></tr> <tr><td>3 PLC</td><td>± -</td></tr> <tr><td>4 PLC</td><td>± -</td></tr> <tr><td>ANGLES</td><td>± -</td></tr> </table>		0 PLC	± -	1 PLC	± -	2 PLC	± 0.25 [.010]	3 PLC	± -	4 PLC	± -	ANGLES	± -	PRODUCT SPEC -	SIZE A3	CAGE CODE 00779	DRAWING NO C-41459	RESTRICTED TO -
0 PLC	± -																	
1 PLC	± -																	
2 PLC	± 0.25 [.010]																	
3 PLC	± -																	
4 PLC	± -																	
ANGLES	± -																	
MATERIAL SEE TABLE	FINISH SEE TABLE	APPLICATION SPEC -	WEIGHT	CUSTOMER DRAWING		SCALE 10:1												
			SHEET 1 OF 1	REV M3														